

# FR SERIES

## ROTATING PULVERIZERS

for excavators from 5 to 32 ton

# No limits to demolition

- Rotation 360°.
- Integrated "relief" valve to avoid pressure peaks on the rotating motor.
- Double-turn ball bearing **(from model FR15 up)**.
- Double motor for extra power and precision **(from model FR15 up)**.
- Excellent speed/power to weight ratio.
- Cylinder fully protected from possible debris during demolition.
- Designed and built to achieve more power.

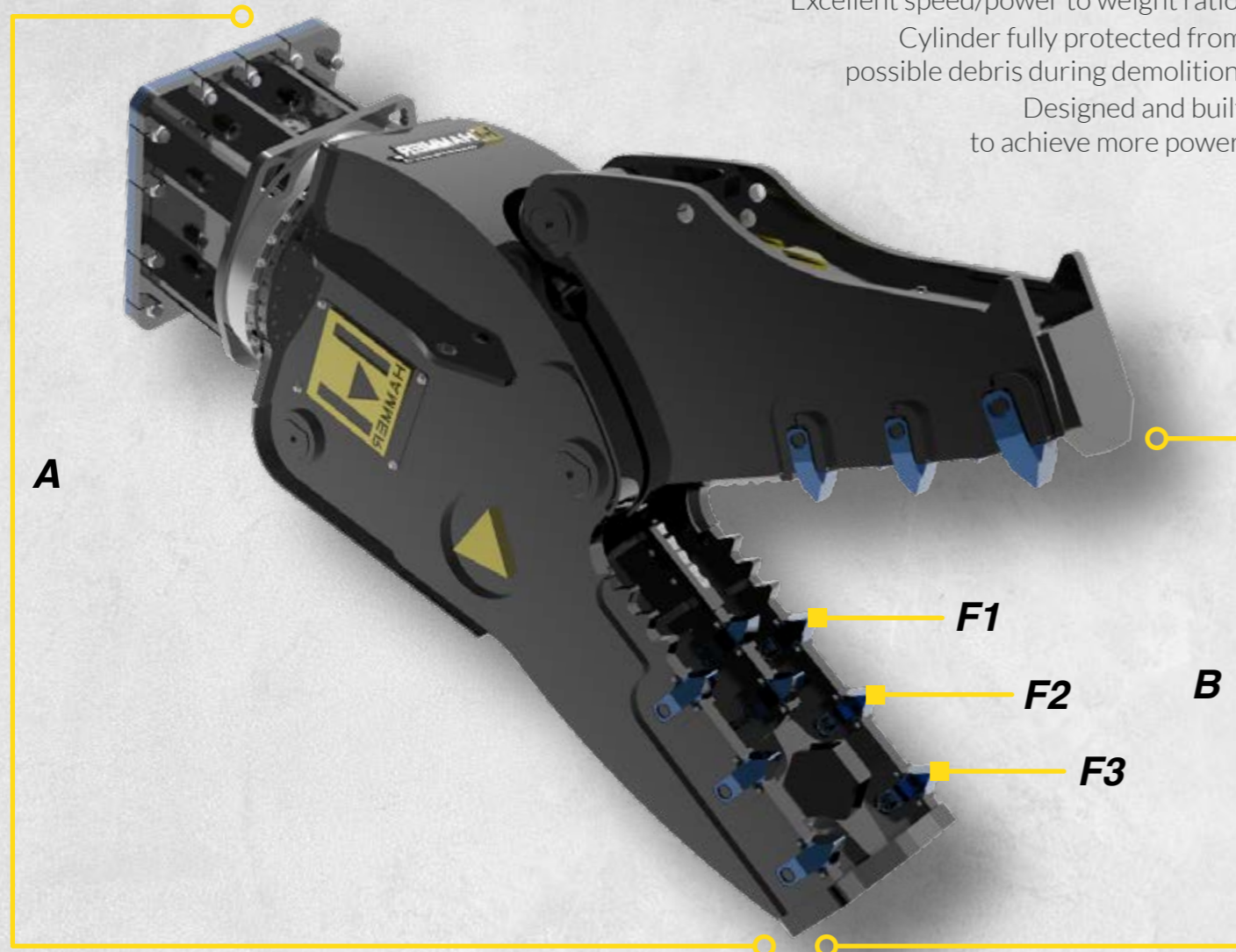

Mining  
& Quarrying



Demolition  
& Renovation



Metallurgic  
Industry



Construction

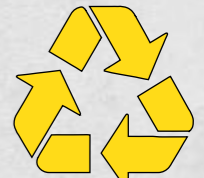

Recycling

**FEEL  
THE  
POWER**

**PRESSURE  
UP TO  
350 BAR**



ALL THE PARTS THAT  
MOSTLY UNDERGO  
WEARING ARE EASILY  
REPLACEABLE

Models		FR04	FR07	FR09	FR12	FR15	FR21	FR26
Carrier weight	t	5-10	8-13	11-15	14-18	16-22	18-27	24-32
Weight	kg	550	790	950	1450	1700	2050	2500
Excavator oil flow capacity	l/min	50-70	60-100	70-110	110-160	140-200	180-230	200-300
Excavator working pressure	bar	280	300	300	300	300	300	300
360° Rotation	°	360°	360°	360°	360°	360°	360°	360°
Rotation oil flow capacity	l/min	5-8	5-8	5-8	20-25	20-30	20-30	20-30
Rotation Pressure	bar	100	100	100	70	70	70	70
A	mm	1400	1570	1600	1850	1950	2200	2300
B	mm	440	600	650	680	710	800	920
Steel blade length	mm	160	160	160	200	200	200	200
F1	t	100	115	140	180	195	234	250
F2	t	50	55	65	110	120	135	140
F3	t	30	35	40	57	65	80	85
Ø Max	mm	20	25	25	35	40	45	50

THE ROTARY PULVERIZERS OF THE NEW FR SERIES HAVE BEEN DEVELOPED FOR PRIMARY AND SECONDARY DEMOLITION. THE JAWS ARE DESIGNED FOR EACH APPLICATION AREA.

All illustrations and numerical data in this catalog are purely indicative and subject to change at our discretion and without notice. We therefore reserve the right to modify them with a view to improving and continuously developing our product.

